

# Articulated feet

base in reinforced polyamide

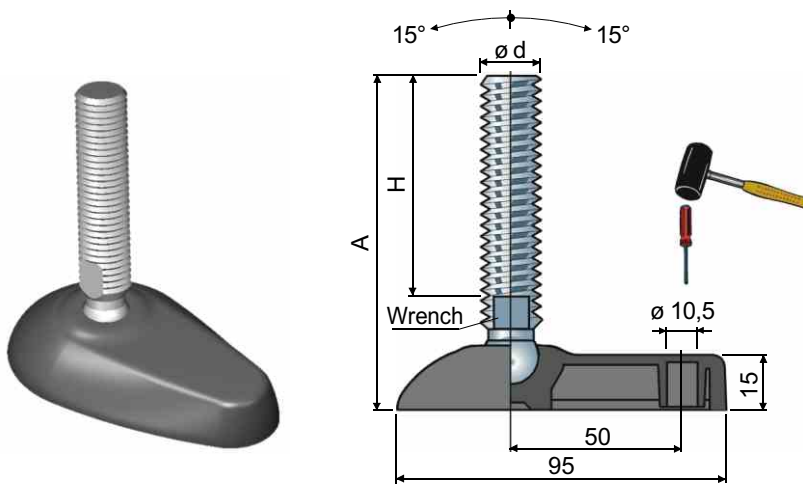

**60x95 Part.27**



$\varnothing d$	A mm	H mm	Wrench mm	Spindle in zinc plated steel		Spindle in stainless steel AISI 304		Max static load N
				Code/Codice	Code/Codice			
M8	72	45	6	27 / 7412	27 / 7413	12000		
	92	65	6	27 / 7414	27 / 7415			
	134	107	6	27 / 7900	27 / 7901			
M10	64	35	8	27 / 7416	27 / 7417	13000		
	99	70	8	27 / 7418	27 / 7419			
	144	115	8	27 / 7420	27 / 7421			
M12	74	43	10	27 / 7422	27 / 7423	14000		
	94	63	10	27 / 7424	27 / 7425			
	109	77	10	27 / 7426	27 / 7427			
	124	93	10	27 / 7428	27 / 7429			
M14	154	123	10	27 / 7430	27 / 7431	15000		
	94	61	12	27 / 7432	27 / 7433			
	124	91	12	27 / 7434	27 / 7435			
	149	116	12	27 / 7890	27 / 7891			
M16	95	60	13	27 / 7436	27 / 7437	17000		
	125	90	13	27 / 7438	27 / 7439			
	140	105	13	27 / 7440	27 / 7441			
	160	125	13	27 / 7442	27 / 7443			
	190	155	13	27 / 7444	27 / 7445			
	200	165	13	27 / 7446	27 / 7447			
M20	125	86	17	27 / 7448	27 / 7449	19000		
	155	116	17	27 / 7450	27 / 7451			
	180	141	17	27 / 7452	27 / 7453			
	245	206	17	27 / 7454	27 / 7455			

**Base material:** reinforced polyamide.  
**Packaging:** 24 pieces.

## Accessories

### Anti-slip pads:

- code: 7632;  
- material: PVC rubber (black);  
- packaging: 24 pieces.

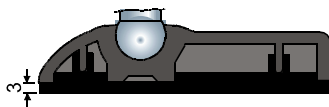

### Nuts UNI 5588-65 -Packaging: 24 pieces.

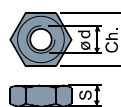

$\varnothing d$	M8	M10	M12	M14	M16	M20
Smm	6,5	8	10	11	13	16
Ch. mm	13	17	19	22	24	30
Zinc plated steel code	7634	7269	7270	7271	7275	7276
Stainless steel code	7635	7272	7273	7274	7277	7278

### Washers UNI 6592-69- Packaging: 24 pieces.

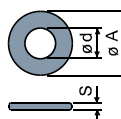

$\varnothing d$ mm	8,4	10,5	13	15	17	21
Smm	1,6	2	2,5	2,5	3	3
$\varnothing A$ mm	17	21	24	28	30	37
Zinc plated steel code	7636	7283	7284	7285	7289	7290
Stainless steel code	7637	7286	7287	7288	7291	7292

## On request

**Bases:** In reinforced polypropylene • other colours • with prebored fixing holes.  
**Spindles with:** Sunk hexagon head • second wrench seat head • hexagon wrench seat • threads with other pitches and lengths.  
**Packaging:** not standard.  
**Assembling of:** Anti-slip pads • nuts • washers.